

Vertical / Horizontal Sliding Automatic Autoclave / Sterilizer

DOOR

- The Sterilizer is supplied with single or double doors made of 304 or 316/L quality stainless steel
- The doors can be horizontal or vertical, automatic sliding type or swinging (radial arm) type as per the customer's requirement
- The doors will have unique arrangement to open manually in case of power failure
- While closing the door, it also automatically opens in case it is obstructed by an object
- These doors are sealed with movable Silicone Rubber gasket with the help of pneumatic pressure

VACUUM SYSTEM

- The system is used for effective air removal from the sterilizer's chamber
- It consists of efficient water ring type vacuum pump, condenser etc

AUTOMATIC PROCESS CONTROL UNIT

- The control unit is based on advance PLC or microprocessor technology with or without SCADA & 21 CFR Part II Compliance
- This unit controls different sterilization cycles with the help of in-built different programmed combinations
- The control units are backed up with manual operation

MATERIAL HANDLING

- Sterilizers can be supplied with stainless steel removable shelves / trays or with loading carriages & trolleys

CARRIAGES & TROLLEYS

- The loading carriage is made from stainless steel 304 or 316/L & it has adjustable shelves which can be positioned according to height of the goods
- It is designed to slide easily from the chamber to trolley

- The trolley is made of Stainless Steel / Mild steel & has its base with four heavy duty castors

STANDARDS

- The sterilizers can be manufactured to comply with any other International Standards



VERTICAL SLIDING STERILIZER

MODEL	CHAMBER SIZE W x H x D in mm	VOLUME Litres	STEAM GENERATOR ELECTRICAL LOAD	
				Kilowatts
Joel VS - 11	450 x 450 x 600	120		12
Joel VS - 21	450 x 450 x 900	180		18
Joel VS - 31	500 x 500 x 1200	300		18
Joel VS - 41	600 x 600 x 900	325		18
Joel VS - 51	600 x 600 x 1200	430		24
Joel VS - 61	600 x 600 x 1500	540		36
Joel HS - 71	600 x 900 x 1200	648		36
Joel HS - 81	600 x 900 x 1500	810		36
Joel HS - 91	900 x 900 x 1200	970		36



Microprocessor P.L.C based control sytem

The control unit is based on 'state-of-art' microcomputer technology, guaranteeing high reliability and safe operation. The computerized control unit ensures a fully automatic operation throughout the entire cycle. No futures intervention is necessary after selecting the parameters and pressing the start button. 'The main cycle phase and the machine's actual parameters are displayed on the LCD panel during the cycle progress.

The main physical parameters of the process i.e., temperature, pressure, time and jacket pressure are controlled and displayed. The keyboard located on the front panel enables the operator to select a program, start and stop the cycle, and allows a trained technician to preset the main parameters using an access code. The control system is easy to use and programmable.

AUTOCLAVE PLC SYSTEM ARCHITECTURE

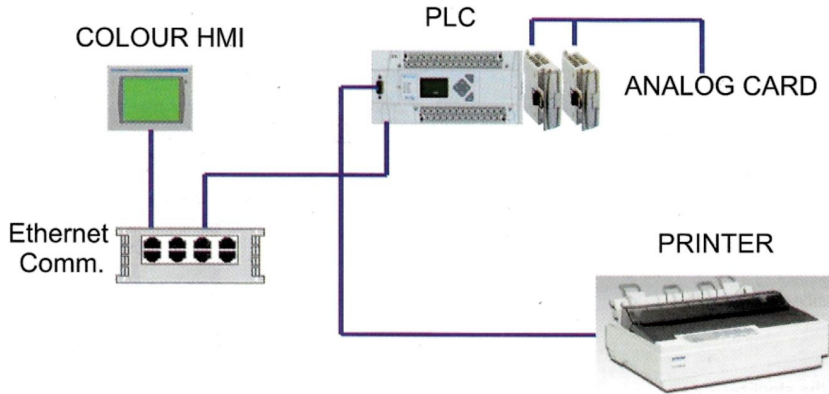

- ➔ 21 CFR Compliance HMI
- ➔ 82 Column Character dot matrix printer
- ➔ Ethernet Protocol Communication
- ➔ Different type of Recipe in HMI
- ➔ Vacuum Leak Test, Bowie Dick Test, HPHV Standard Cycle incorporated in HMI
- ➔ SCADA Compliance

Sophisticated

SOPHISTICATED

High quality materials combined with smart construction lead to sophisticated system solutions for efficient and economic operation.



SOPHISTICATED

CSSD

CSSD Design

The design of a central sterile supply department requires many considerations proper Design of areas within the Department choosing the right equipment and understanding the needs.

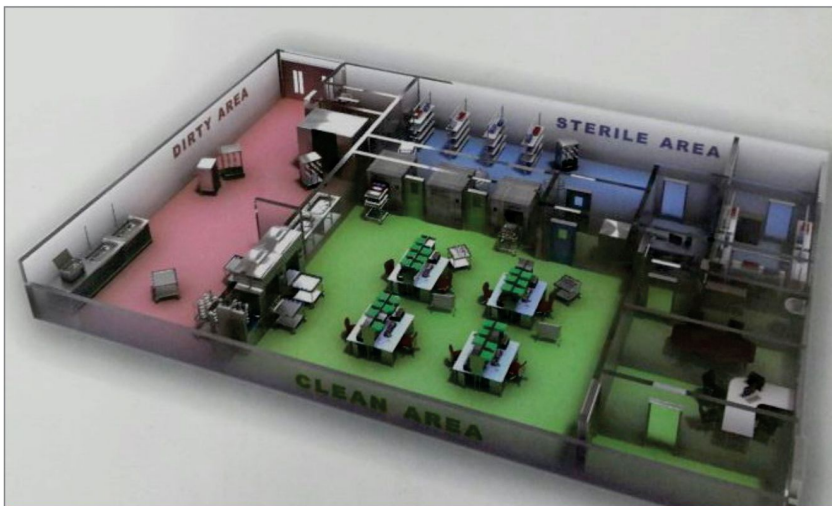

CSSD DESIGN

Horizontal Rectangular Autoclave / Sterilizer

CENTRALIZED CONTROL POINT

- Multi-port operating valve, control for the entire cycle of the operation
- Permits two exhaust speeds, fast & slow
- Easy to read compound gauge for the chamber and pressure gauge for the jacket
- Smooth operation

SAFETY FEATURES

- Self locking safety door cannot be opened while chamber is under pressure
- Gauge glass tube with automatic closing safety valve
- Heat resistant SILICONE door gasket
- Pressure switches (on electric models) economize power consumption
- Low water protection system, to protect the electric heaters
- Temperature gauge / Digital temp. Indicators / controllers (optional)
- Vacuum breaker / dryer
- Safety valve for the Jacket / boiler
- Hydraulically test to 2.5 times the designed working pressure
- Powerful ejector for drying
- Insulated with resin bond fiber glass wool covered with M.S. / S.S. 304 sheet



STANDARD MODEL

MODEL		JOEL 7	JOEL 16	JOEL 24	JOEL 30	JOEL 36	JOEL 45	JOEL 98	JOEL 128
Chamber	W	450 (18)	600 (24)	600 (24)	600 (24)	900 (36)	900 (36)	1050 (42)	1200 (48)
Dim.	H	450 (18)	600 (24)	900 (36)	900 (36)	900 (36)	900 (36)	1200 (48)	1200 (48)
	D	900 (36)	1200 (48)	1200 (48)	1500 (60)	1200 (48)	1500 (60)	2100 (72)	2400 (84)
Chamber Vol.	Lit.	182	432	648	810	972	1245	2646	3456
External Dimension	W	650	800	800	800	1200	1200	1250	1400
	H	1800	1800	2000	2000	1800	1800	2000	2000
	D	1200	1400	1400	1700	1400	1700	2300	2600

High Speed / High Pressure Autoclave / Sterilizer

TYPICAL FEATURES

The Sterilizers designed for a standard working pressure of 1.2 kg/cm i.e., 121°C or an optional High Speed (flash) working pressure of 2.1 kg /cm i.e., 134°C which substantially reduces cycle time.

Our high efficiency Steam Sterilizers are designed for maximum thermodynamic efficiency and robust in construction Built with an inner chamber of AISI 304/316 grade stainless steel, jacket of AISI 304 grade stainless steel, door of AISI 304 grade stainless steel, the strong argon arc welded chamber and jacket ensure a leak proof construction. Mounted on a corrosion resistant stand further ensures greater durability.

Working on the principle of downward displacement of air, the sterilizer assure you that only a minimal quantity of water and steam are required for optimum sterilization. A steam trap is provided for effective, economical removal of air and condensate from the chamber. This help to achieve sterilization temperature quicker. The option of a steam generator feed water pump assists uninterrupted operation.

A powerful ejector fitted in the multi-port operating valve circulate air in the chamber for vacuum drying. With minimum heat loss the sterilizer enables a pleasant, comfortable, working environment.

CENTRALIZED CONTROL POINT

- Multi-port operating valve / Solenoid valve, control for the entire cycle of the operation
- Permits two exhaust speeds, fast & slow
- Easy to read compound gauge for the chamber and pressure gauge for the jacket
- Smooth operation

SAFETY FEATURES

- Self locking safety door cannot be opened while chamber is under pressure
- Gauge glass tube with automatic closing safety valve
- Heat resistant SILICONE door gasket
- Pressure switches (on electric models) economize power consumption
- Low water protection system, to protect the electric heaters
- Temperature gauge / Digital temp. Indicators / controllers (optional)
- Vacuum breaker / dryer
- Safety valve for the Jacket / boiler
- Hydraulically test to 2.5 times the designed working pressure

Horizontal Cylindrical Autoclave/Steam Sterilizer



Ethylene Oxide (E.T.O) Sterilizer

- M.O.C. Chamber - SS 304 / 316
- Outer body - powder coated / fully ss 304
- Chamber Thickness: 6mm
- Internal: Mirror Finished
- Operating Gas Pressure: 1 Kg/Cm²
- Test Pressure: 2 Kg/Cm²
- Manual system available in case of auto system fail
- Pneumatic Solenoid Valve would be provided for automated system
- Safe use of cartridge - cartridge is punctured only when proper negative pressure build-up
- Cartridge puncture inside chamber automatically by pneumatic cylinder
- Mode of hitting - electric immersion heaters operated by single phase
- Operating temp 40 to 55°C
- Digital display to show running process with time & temperature during entire cycle
- Compound gauge - to show vacuum & air pressure
- Vacuum pump - Kirloskar heavy duty watering vacuum pumo 1 hp.
- Easy to handle - material can be easily loaded using the basket provided with sterilizer
- Usage - all kind of surgical instruments and ideal for sensitive medical equipments which are not sterilized. In steam sterilizers



ETO STERILIZER

STANDARD SIZES

Sr. No.	Size	Cartridge Used
1	300 x 300 x 600 MM	40 gm
2	300 x 300 x 750 MM	40 gm
3	300 x 300 x 1200 MM	100 gm
4	300 x 300 x 1350 MM	100 gm
5	450 x 450 x 1050 MM	170 gm
6	400 x 400 x 1350 MM	170 gm

Multicolumn Distillation Plant

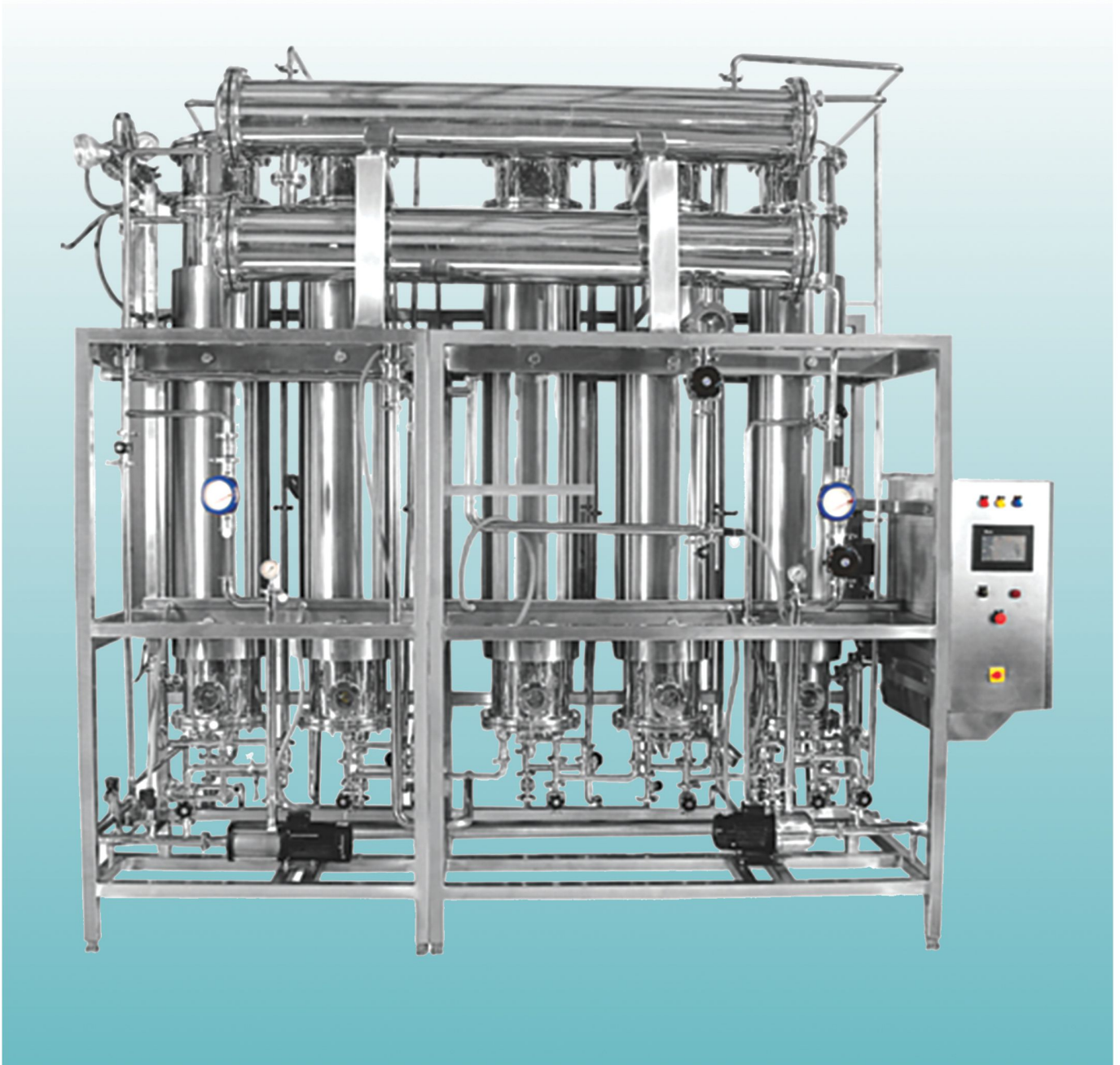

Uses Superior three-punch entertainment technology for producing sterile, pyrogen free USP grade WFI for manufacture of critical sterile dosage forms.



Multicolumn Distillation Plant

DESCRIPTION

'Joel' Multi Column Distillation Plant is a key system for cGMP Standard. MCDP is the perfect solution for high purity sterile pyrogen free distill water. The vapour with high velocity & under pressure passes over a 'SPECIALLY DESIGNED SPIRAL BAFFLE' System which develops tremendous centrifugal force & thus eliminates any chances of pyrogens in the carry over vapours. It is available in capacities from 50 Ltrs/Hr. The Water for injection (WFI) produced from MCDP is according to FINNAQUA Design & it is low maintenance & low operational costs.

SALIENT FEATURES

- All Contact Parts are in AISI 316/AISI SS 316L
- To assure WFI quality & increase the life of equipment Inner Contact Surfaces are electro polished
- Double Tube Sheets is constructed in the first column where boiler steam is present
- Sanitary Tricolor fittings are used for quick & easy preventive maintenance
- All pipes & Tubes are seamless & gaskets made from PTFE material
- PLC based system for automated operation with all required inter locks & validated logic with skid mounted AISI SS 304 control panel with printing facility

OPTIONAL FEATURES

- Fully Automatic Plant supplied with boiler steam, cooling water flow rate & feed water flow rate
- All pipes & tubes are as per ASME & BPE stamping with less than 0.5 Ra
- Double tube sheet for all pre heaters & both top coolers
- Magnetic Float Switch is provided for Surge Tank to control Water i.e., High level & Low Level
- Air Eliminator is provided for removing toxic gases

Technical Specification

MODEL	No. OF COLUMNS	INDUSTRIAL STEAM AT 3 BAR PRESSURE				INDUSTRIAL STEAM AT 8 BAR PRESSURE				APPROX. DIMENSION (mm) L x W x H	EST. WT. Kg
		CAPACITY	SUPPLY STEAM	COOLING WATER	FEED WATER	CAPACITY	SUPPLY STEAM	COOLING WATER	FEED WATER		
		Ltrs/Hr.	Kg/Hr.	Ltrs/Hr.	Ltrs/Hr.	Ltrs/Hr.	Kg/Hr.	Ltrs/Hr.	Ltrs/Hr.		
J / M-80	4	80	40	120	90	145	70	180	165	1400 x 900 x 2050	350
J / M-150	4	150	48	180	175	285	85	350	330	2100 x 1300 x 2600	800
J / M-300	4	300	97	365	545	570	170	700	1000	2100 x 1300 x 2600	900
J / M-500	5	500	130	605	575	920	275	1130	1060	2800 x 1300 x 3200	1250
J / M-1000	5	1000	238	1265	1150	1920	575	2360	2210	3300 x 1600 x 3250	2000
J / M-2000	6	2000	440	900	2300	3835	1150	4720	4410	4400 x 1650 x 3800	3400
J / M-3000	6	3000	660	650	3450	5500	1650	6770	6325	4900 x 1800 x 4300	6800



JOEL PROCESS
EQUIPMENT PVT. LTD.

Pure Steam Generator



Ideal for generation of sterile pyrogen free steam used in the steam sterilizers and for SIP of vessels, pipelines, lyophilizers, etc.



**JOEL PROCESS
EQUIPMENT PVT. LTD.**

Pure Steam Generator

DESCRIPTION

'Joel' Pure Steam Generator meets the ASME, BPE & cGMP specifications. Pure Steam Generator produces pyrogen from sterile steam for sterilization which meets international standards including Indian, British & United States Pharmacopoeia. The Pure steam generated is widely used in medical field, biochemical, piping & tank & sterilization. The Pure steam produced from PSG is according to FINN AQUA Design & it is low maintenance & low operational costs.

SALIENT FEATURES

- All Contact Parts are in AISI 316/AISI SS 316L
- To assure High Purity Steam quality & increase the life of equipment - Inner Contact Surfaces are electro
- Double Tube Sheets is constructed in the first column where boiler steam is present
- Sanitary Tricolor fittings are used for quick & easy preventive maintenance
- All pipes & Tubes are seamless & gaskets made from PTFE material
- PLC based system for automated operation with all required inter locks & validated logic with skid mounted AISI SS 304 control panel with printing facility
- High Purity Flow Diversion Valve is provided for protection of High Purity Steam Quality
- Insulation is made with 3cm Mineral Wool covered by AISI 304 Stainless Steel sheet
- Magnetic Control System is provided for first column to control Water i.e. High Level & Low Level
- Fast response to Pure Steam demand.

OPTIONAL FEATURES

- Fully Automatic Plant supplied with boiler steam & feed water flow rate
- All pipes & tubes are as per ASME & BPE stamping with less than 0.5 Ra
- Double tube sheet for all pre heaters & both top coolers
- Magnetic Float Switch is provided for Surge Tank to control Water i.e., High level & Low Level
- Air Eliminator is provided for removing toxic gases

Technical Specification

MODEL	CAPACITY	FEED WATER	INDUSTRIAL STEAM DRY & SATURATED	OUTPUT	EST. WT.	DIMENSIONS
	Kg/Hr.	7 Kg/cm ²	6 Kg/cm ²	3 Kg/cm ²	Kg	L x W x H
J / PSG 100	100	120	125	100	185	950 x 900 x 2450
J / PSG 150	150	180	185	150	225	1100 x 1100 x 2450
J / PSG 200	200	240	250	200	300	1100 x 1100 x 2450
J / PSG 300	300	360	375	300	330	1100 x 1100 x 2450
J / PSG 500	500	600	625	500	530	1500 x 1225 x 3050
J / PSG 750	750	900	925	750	650	1500 x 1300 x 3050
J / PSG 1000	1000	1200	1250	1000	800	1600 x 1500 x 3550
J / PSG 1500	1500	1800	1875	1500	1200	1550 x 1000 x 3600

- Plant steam 6 bar-dry and saturated
- Feed water (purified water) at 30 to 35 deg. C

Superheated Water Spray Sterilizer

DESCRIPTION

Our plant assure sterilization in conformity with good manufacturing practices for LVPs, SVP etc. and in accordance with the cGMP issued by FDA. In short, excellent engineering coupled with efficient manufacturing.

Superheated water shower method is an efficient process for the sterilization of sealed containers.

The process water is circulated through sanitary pumps via heat exchanger. Industrial steam or cooling water is admitted to the external heat exchanger.

Circulation pump is designed for high circulation performance, uniform temperature rise during heating and optimal temperature distribution during sterilization.

External heat exchanger is FDA-compliant double-tube sheet heat exchanger or plate heat exchanger.

FEATURES

- The panel use LCD touch screen control.
- Program Flow: Use PLC control, for ease of operation and provide three sterilization programs or by customer specifications.
- Simple & safe operation: The automatic programs provide with complete and safety control to ensure safe operating condition.
- Temperature recorder for continuous monitoring and recording of the sterilization process.

SPECIFICATION

- Sterilization chamber in 316, 316 L stainless steel.
- Piping and valves directly connected with chamber in stainless steel.
- Chamber piping all valves and fittings are sanitary class.
- Insulation by Glass wool.
- Automatic temperature controller.
- Automatic temp. Recorder - 6 points or 12 points.
- Sealed Door Packing: Use heat-resistant silicon rubber material ring packing.
- Absolute air vent filter for prevention of sterilized product contamination.
- One door or pass through type double doors.
- Single wall (cylindrical chamber) or double walls (parallel equipped chamber) body.
- All control and safety components are adapted to the higher temperature and pressure.



Table Top Autoclave

APPLICATIONS FOR:

JOEL Table Top High Pressure High Vacuum High Speed Sterilizers are ideal for all applications requiring rapid, reliable and total destruction of all types of living Microorganisms. Ideal for Research lab, Hospitals, Dental clinics, Operation theatres, QC/Micro etc.

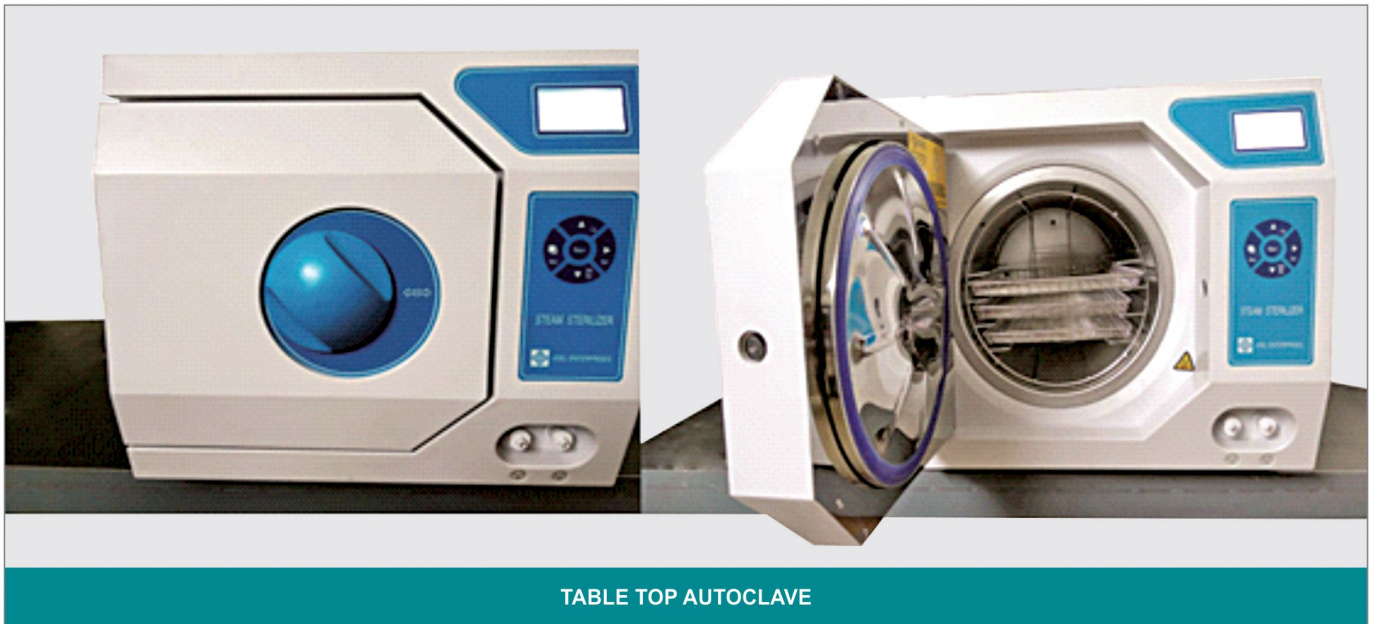

TABLE TOP AUTOCLAVE

MODEL AVLABLE ARE IN LETERS : JE-T- 8 / 12 / 16 / 18 / 23. (B – CLASS & N CLASS)

FEATURES & ADVANTAGES:

- Automatic computer control, LCD dynamic display, fault self – diagnosis, display the error code.
- Reference European class B standard, three pre vacuum and vacuum deep drying function, to make the sterilization and drying sterilization, drying to achieve the best working conditions.
- Preset sterilization procedures, sterilization and the drying time can be adjusted.
- SS 316 L stainless steel containers and a sealing cover, double pressure protection safety door lock.
- Start working procedures prevent when door is not locked well.
- Safety pressure protection lock, automatic induction sterilizing cavity pressure, can't open door during sterilization process.
- Built –in independent steam generator, fast saturated steam, so that the high temperature steam fully reaches every corner.
- Simple and convenient operating interfaces, LCD dynamic display, display the status information in real time.
- Open type top water tank, filling and cleaning for user.
- With liquid sensor for water level, to remind user to add water or drainage.
- The built-in safety valve, automatically exhaust and unloading pressure when over pressure.
- Equipped with temperature protection device, in the cavity wall temperature and steam generator device is too high will automatically disconnect.
- With B&D test, Helix Test, and Vacuum test program.
- With optional external printer.
- The optional USB function and U disk, the data stored in the U disk, connect the computer to view and save.

Vertical Autoclave Single Lever

- Thermal Printer with FO Value Calculation.

OPTIONAL :

- 21 CFR Part II Compliance
- SCADA Compliance

APPLICATION :

For use in Microbiology, Hospital, QC & Research laboratories, Pharmaceutical Industry etc.

Fully Automatic Model : Temperature automatically maintained by digital Controller, which controls / pressure and temperature with auto air purge, digital timer, auto steam exhaust, low water level cutoff.

- Vertical Triple wall design has triple chamber for steam and water.
- Working chamber made of Stainless Steel 316 grade of 3 mm thickness.
- Outer cover made of stainless steel 1mm thick.
- Lid, flange & bottom sheet also made of stainless steel. All joints argon welded.
- Joint less silicon gasket, heavy duty industrial flange heater.
- Pressure range : 15 to 22 PSI, factory set at 15 PSI.
- Lid fitted pressure gauge 0- 30 PSI, safety spring loaded pressure valve, And steam release valve.
- Hydraulically tested at 60 PSI.
- Single lever operated Door.
- Electrical : 230 V/ 32A / 50Hz.
- Temperature Control : Microprocessor based digital display.
- Temperature Sensor : PT – 100 Temperature Range : 121° C to 125° C
- Temperature resolution : 0.1° C. Temperature Accuracy : ± 0.5° C

SAFETY FEATURES:

- Safety valve for chamber & Jacket.
- Automatic purging system.
- WLC System for Heater protection.
- Separate Ball Valves for water Inlet & Drainage.
- Dial type Pressure Gauge to indicate pressure in the Chamber.
- Pressure Release valve to release excess pressure from chamber.
- Audio visual Alarm system after completion of cycle.
- Gauge glass facility for water visibility.



VERTICAL AUTOCLAVE SINGLE LEVER